

The **220/PL 600A** automatic bollards are the products with the best quality/price ratio of the hydraulic PILOMAT range. The current models are the result of the development of more than 15 years of experience.

GENERAL FEATURES

- **the cost of the product:** made with industrial criteria of 500 units per batch, optimising production costs while offering a high-quality technology;
- **hydraulic movement:** The most reliable technology for most intense use at all temperatures and weather conditions;
- **hydraulic pump in the control unit:** for the promotion of quicker service;
- **patented system for the protection of handling:** to maximise the reliability of operations due to impact by vehicles on the cylinder that is put in motion;
- **wide range of optional configurations:** custom colours, flashing lights integrated into the head, intermittent sound signal, 220V solenoid valve (in case of power failure, the PILOMAT is lowered, releasing the gate), heat resistance installations in locations with harsh winter temperatures, UPS unit for operation in the temporary occurrence of power failure, equipment control, equipment accident prevention (see accessories and optional items).

RECOMMENDED USES

Pedestrian Areas - Private Car Parks – Parking Company
Private Driveways – Driveway Businesses – Commercial Driveways

MOVING CYLINDER	FE 370 STEEL (IRON) - AISI 304 STAINLESS STEEL
MOVING CYLINDER NOMINAL DIAMETER	220 mm
MOVING CYLINDER HEIGHT	600 mm
MOVING CYLINDER FE 370 STEEL THICKNESS	4 mm
MOVING CYLINDER STAINLESS STEEL THICKNESS	AISI 304 :4 mm
MOVING CYLINDER FE 370 STEEL FINISH	POLYESTER POWDER PAINT – STANDARD GREY ANTHRACITE
MOVING CYLINDER STAINLESS STEEL FINISH	AS ABOVE, OR BRUSHED
REFLECTING ADHESIVE STRIP	YES - HEIGHT 55 mm
RISING SPEED	12 cm/sec
LOWERING SPEED	25 cm/sec
MANUAL EMERGENCY LOWERING	YES (VERSION WITH RELEASE NO 220 = AUTOMATIC LOWERING)
SAFETY REVERSAL PRESSURE SWITCH	YES
CONNECTION LINE TO CONTROL UNIT	STANDARD 10 mt (MAXIMUM LENGTH: 20 mt)
HYDRAULIC PUMP	IN THE CONTROL UNIT
PROTECTION CLASS	IP 67
TYPE OF USE	INTENSIVE - LIFE AVERAGE 2.000.000 MOVEMENTS - 2.000 MOVEMENTS/DAY
IMPACT RESISTANCE (WITHOUT DEFORMATION)	30.000 J
BREAKOUT RESISTANCE	150.000 J
OPERATING TEMPERATURE	- 40°C + 70°C (FOR LOW TEMPERATURES SEE HEATING RESISTANCE)
NOMINAL PILOMAT WEIGHT (WITHOUT PIT)	65 kg
NOMINAL WEIGHT OF STANDARD PIT, WITH COUNTER-FRAME AND BRACKETS	34 kg

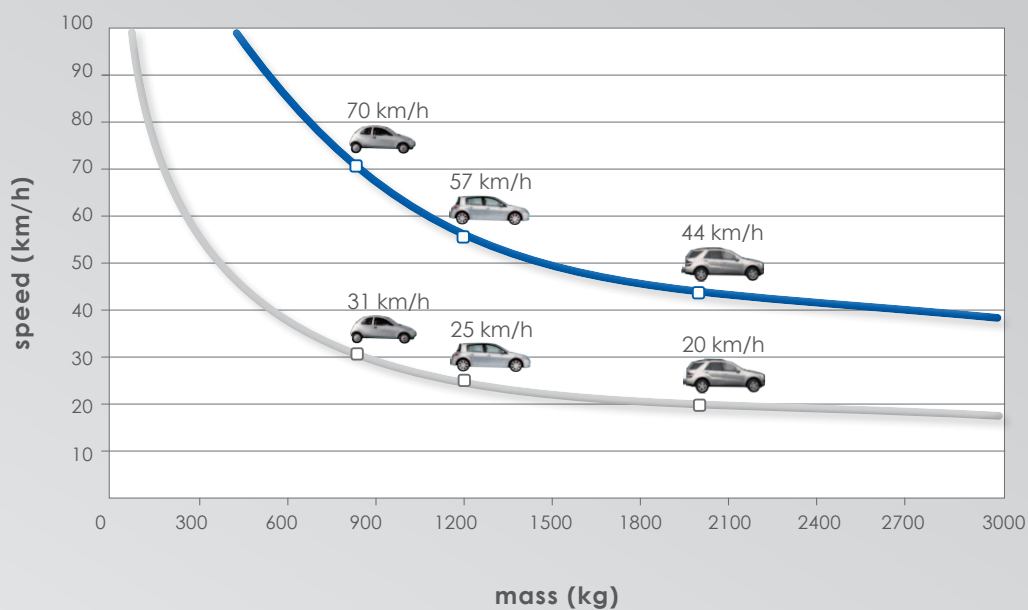

BREAKOUT RESISTANCE 150.000 J

IMPACT RESISTANCE 30.000 J



MAIN DIMENSIONS

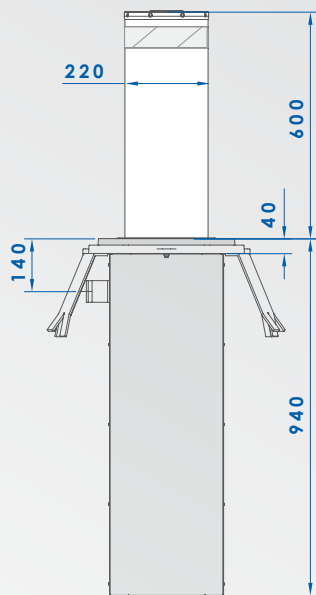

220/PL 600A

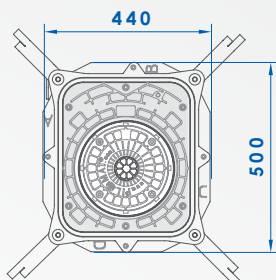

OPTIONAL ITEMS



INTEGRATED FLASHING LIGHT IN THE HEAD



RAL PAINTING ON REQUEST



ANONYMOUS HEAD



NEUTRAL REFRACTED STRIP

BUZZER ACOUSTIC SIGNAL DURING THE MOVEMENT