

The **275/P10 800A** automatic bollards are the top line products of PILOMAT range. The current models are the result of the development of more than 15 years of experience.



**GENERAL FEATURES**

- **hydraulic movement:** The most reliable technology for most intense use at all temperatures and weather conditions;
- **built-in hydraulic pump in the bollard:** This philosophy has many advantages, particularly in installations in locations with severe winter temperatures or when the installation requires a considerable distance (up to 80 metres) between the PILOMAT and the control unit;
- **patented system for the protection of handling:** to maximise the reliability of operations due to impact by vehicles on the cylinder that is put in motion;
- **wide range of optional configurations:** custom colours, flashing lights integrated into the head, intermittent sound signal, 220V solenoid valve (in case of power failure, the PILOMAT is lowered, releasing the gate), heat resistance installations in locations with harsh winter temperatures, UPS unit for operation in the temporary occurrence of power failure, equipment control, equipment accident prevention (see accessories and optional items).

**RECOMMENDED USES**

PILOMAT 275/P10 800A is a variant of PILOMAT **P SERIES**, which has the same general features (pag 24), but the cylinder is thicker in order to increase the resistance of breakage. It is typically used in business and industry, combined with the classical gates in order to improve the level of passive safety, preventing theft of vehicles and its cargo inside the area.

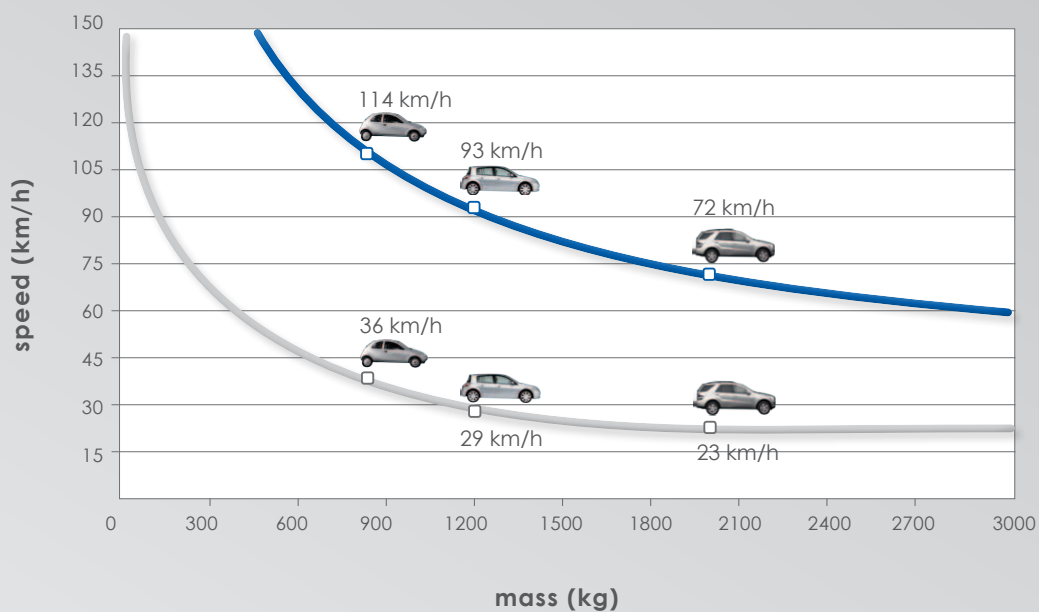
MOVING CYLINDER	FE 370 STEEL (IRON) – AISI 304 STAINLESS STEEL
MOVING CYLINDER NOMINAL DIAMETER	275 mm
MOVING CYLINDER HEIGHT	800 mm
MOVING CYLINDER FE 370 STEEL THICKNESS	10 mm
MOVING CYLINDER STAINLESS STEEL THICKNESS	-
MOVING CYLINDER FE 370 STEEL FINISH	POLYESTER POWDER PAINT - STANDARD GREY ANTHRACITE
MOVING CYLINDER STAINLESS STEEL FINISH	-
OTHER MOVING CYLINDER FINISH	RIBS ON CYLINDER SURFACE
REFLECTING ADHESIVE STRIP	YES - HEIGHT 55 mm
RISING SPEED	15 cm/sec
LOWERING SPEED	25 cm/sec
MANUAL EMERGENCY LOWERING	YES (VERSION WITH RELEASE NO 220 = AUTOMATIC LOWERING)
SAFETY REVERSAL PRESSURE SWITCH	YES (EXCLUDABLE)
CONNECTION LINE TO CONTROL UNIT	STANDARD 10 mt (MAXIMUM LENGTH: 80 mt)
HYDRAULIC PUMP	BUILT-IN INTO THE PILOMAT
PROTECTION CLASS	IP 67
TYPE OF USE	INTENSIVE - LIFE AVERAGE 2.000.000 MOVEMENTS - 2.000 MOVEMENTS/DAY
IMPACT RESISTANCE (WITHOUT DEFORMATION)	40.000 J
BREAKOUT RESISTANCE	400.000 J
OPERATING TEMPERATURE	- 40°C + 70°C (FOR LOW TEMPERATURES SEE HEATING RESISTANCE)
NOMINAL PILOMAT WEIGHT (WITHOUT PIT)	150 kg
NOMINAL WEIGHT OF STANDARD PIT, WITH COUNTER-FRAME AND BRACKETS	66 kg



**BREAKOUT RESISTANCE 400.000 J**

**IMPACT RESISTANCE 40.000 J**

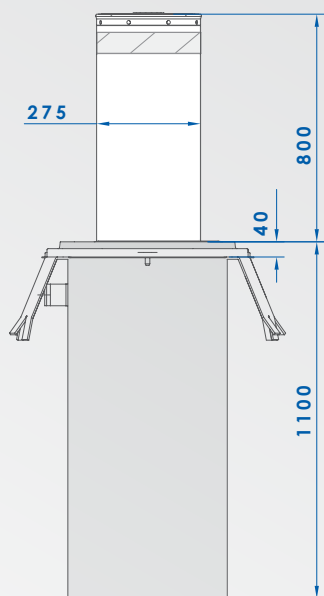
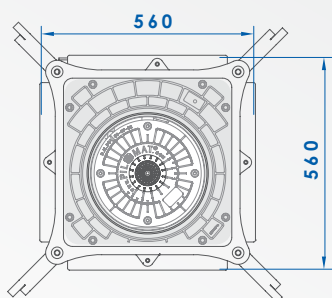
**MAIN DIMENSIONS**

**275/P10 800A**

**OPTIONAL ITEMS**

-  INTEGRATED FLASHING LIGHT IN THE HEAD
-  RAL PAINTING ON REQUEST
-  ANONYMOUS HEAD
-  NEUTRAL REFRACTED STRIP
-  RIBS ON CYLINDERS SURFACE
- BUZZER ACOUSTIC SIGNAL DURING THE MOVEMENT
- HYDRAULIC PUMP WITH BIODEGRADABLE OIL
- CONNECTION LINE, UP TO 80 MT
- E.F.O. CIRCUIT FOR EMERGENCY LIFT, 1"
- ANTI-TAMPERING SCREW KIT FOR CROWN