

**JUNIOR 624** is an electro-mechanical geared motor to open and close residential sliding gates having a max. weight of 400 kg. It is an electro-mechanical gate operator fitted with a 24 Vdc low voltage motor, designed and produced in full compliance with the EN 12445, EN 12453 Safety Norms and the EN 13241-1 Product Norm: in case of an obstacle on opening, gate travel is reversed to allow the obstacle removal; on closing, travel is reversed and gate is driven to the fully open position.

The gear box is made of pressure cast aluminium; the gear coupling is supported by shielded, rolling bearings; the fast rotating shaft and worm gear, as well as the slow rotating shaft, that is driven by the crown gear, are made of steel; the crown gear is made of strengthened plastic material. Gear movements and inertia are cushioned by a shock absorber made of elastic, oil-proof material, ensuring the high quality standards of this product, tested on real field applications.

All the inner functional parts are fitted with seals and oil rings, and are lubricated by a hydraulic oil. Cable inlet is through a rubber duct at the foot of the gear box.

The mains supply terminals are protected by a fuse, thus providing maximum safety on maintenance. Junior 624 can be overridden by pulling the release handle open through an encoded key. Whenever the release handle is opened, power is disconnected, but programme parameters are retained. Rechargeable back-up batteries can be supplied on request, allowing only a few open/close operations in case of power failure. Junior 624 can be installed either by 4 expanding bolts into the ground or by means of an anchoring base plate with 4 log bolts; this kind of fitting allows the unit to be adjusted to the most suitable height as required.

The functioning of the whole installation is monitored by the diagnosis led that is factory-fitted to the operator cover: the blue light, either steady or flashing, indicates correct functioning as pre-programmed in the control panel; if the light is amber in colour, steady or flashing, malfunctioning is the case and maintenance is required. Elpro 62 is the control PCB that operates this unit and it is standard incorporated in it in the top section, right under the cover, which can be taken off by removing two lateral fixing screws; the PCB is protected by a removable clear cover. The limit stop switch is factory fitted and is magnetic, of the kind "Hall-effect". The magnets, permanent type, are to be fitted into a metallic bracket, suitably designed to this purpose and mounted to the gate toothed bar; a mechanical version can be supplied on request.

Junior 624 can be either right- or left-handed mounted. Either option is made switch-abled and selection occurs at the time of installation, no need to adjust the electric motor phase or the limit switches.

It is designed in the circuitry of the control board that gate travel and slow down starting times are self learned through a dedicated button switch; whereas torque control, dwell time and pedestrian partial opening can be adjusted through potentiometers to meet the application requirements. Dip-switches allow to select the following options: automatic or semi-automatic modes, slow down in/out of service, impact sensitivity, automatic closing on engaging the photocells, DSA control of the safety devices, right- or left-handed installation options and double mount with a second sliding gate.

Tested and certified in compliance with the existing European Norms EN 12445 and EN 12453, CE marking, type tested according to ITT PDC No.0976-2010.

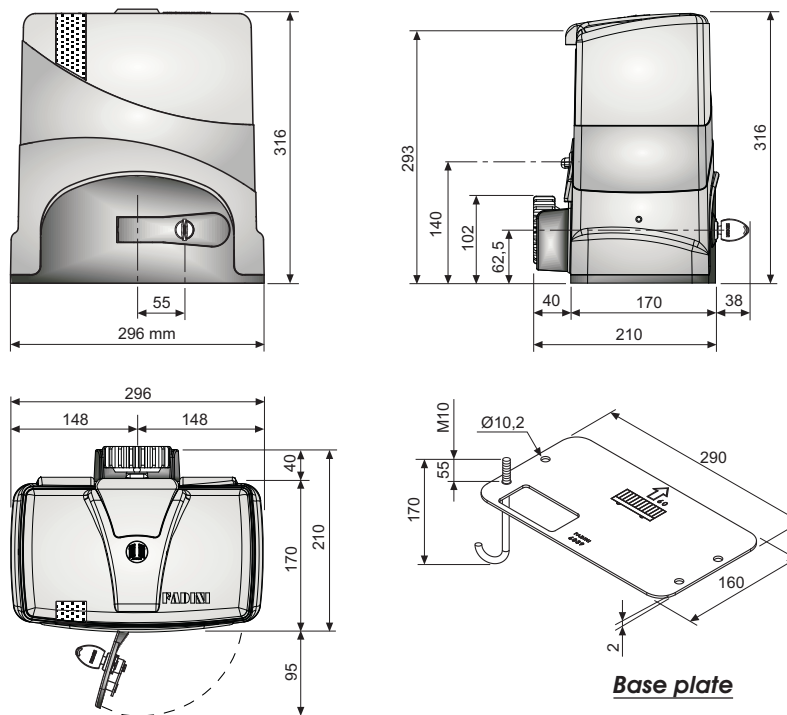

**TECHNICAL DATA**

Supply voltage	230 V - 50 Hz	Motor revolutions	3.000 rpm
Motor power supply	24 Vdc	Speed	12 m/1'
Max. absorbed power	220 W	Gear ratio	1:61
Max. absorbed current	6,3 A	Protection standards	IP 54
Max. torque	400 N	Oil type	Oil Fadini - Item 706L
Max. gate weight	400 kg	Working temperature	-20 °C +50 °C
Anchoring base plate c/w 4 log bolts	M10	Weight	11 kg

**PERFORMANCE**

Frequency of use	Intensive
Duty cycle	30 s opening/closing 30 s dwell
Complete cycle time	120 s = 30 cycles/hour

Notified institute and laboratory for product according to DM 2004/108/EC:  
**Istituto di Ricerche e Collaudi M.Masini srl**  
 Via Moscova, 11 - 20017 Rho (MI)  
 - CE 0068 - Notified  
 - SINCERT 047A Certified - SINAL 0019 Certified  
 - Conforming to the following Standards: UNI EN 13241-1, UNI EN 12604, UNI EN 12605, UNI EN 12445, UNI EN 12453

