

SmartLane®

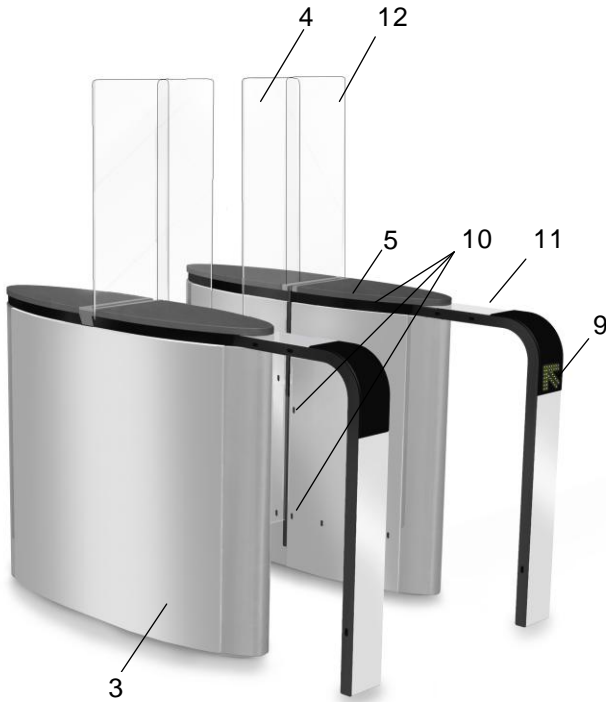

Designed for heavy use in intra-building sites, the SmartLane901 security entrance lane ensures an effective, reliable anti-fraud and rapid control of pedestrians taller than 1 m, with or without luggage, in one direction of passage. The opposite direction offers a dissuasive passage control.

With its mechanical design and its embedded electronics, the equipment guarantees high levels of safety (prevention of fraud) and safety (protection of the users during operation).

The gate can be installed in series, in which case it is necessary to define left-hand, right-hand and intermediate gates (with a mobile leaf on both sides of the gate).

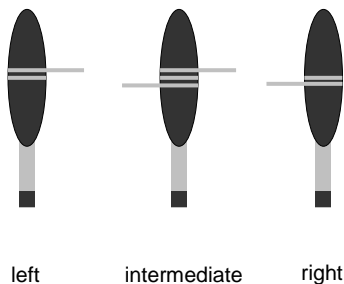

Description

1. Self-supporting frame (made from galvanized steel) integrating the electromechanical drive assembly for each mobile leaf, the photoelectric cells for the detection of the presence of users, and the control boards.
2. Brushed AISI 304L stainless steel housing.
3. Brushed AISI 304L stainless steel side panels with key lock, allowing easy access to the electromechanical unit and the control boards.
4. Monolithic clear 12 mm thick tempered glass leaf, retracting completely into the body on opening.
5. Black laminate top cover (stainless steel around the fixed glass if any: i.e. for mobile leaf height > 1000 mm).
6. Electromechanical unit consisting of:
 - A three-phase asynchronous reduction motor.
 - Secondary transmission with crank-and-rod linkage ensuring perfect mechanical locking in both extreme positions.
 - A device for automatic opening of the mobile leaves in the event of a power failure.
 - A variable-speed controller ensuring progressive accelerations and gradual decelerations, for a movement without vibration and for protection of the mechanism and the users in the event of contact with the mobile leaves.
 - An inductive sensor controlling the position of the mobile leaf.
7. Dual AS1300 control board ensuring the management of the gate, as well as for supporting various control options and/or accessories. A LCD allows navigation in the drop-down menus and the modification of certain parameters.
8. Transfer of information through potential-free contacts: passage authorization, passage information, defect, state of the gate (free, prohibited, alarm ...).
9. Orientation pictogram, indicating the state of the gate to the user (in service or out of service)....
10. Photoelectric cells for detecting presence, ensuring the control of the movement of the users through the gate as well as their safety during the movements of the mobile leaves.
11. Extension, allowing to increase the level of safety by increasing the number of detection cells and to integrate an optional access control system (badge reader for example).
12. Fixed glass preventing climbing over the gate.

Technical characteristics

- Electrical supply: single-phase 230 VAC + ground, 50/60 Hz.
(do not connect to a floating network or to high impedance earthed industrial distribution network)
- Nominal consumption per gate: 250 W.
- Three-phase asynchronous 120 W motor.
- Ambient T° of operation: from 0 to +50°C.
- Relative humidity max: 95%, without condensation.
- Net weight of a gate, depending on its configuration (left, right, intermediate): between 160 and 250 kg.
- Opening time: 0.3 s.
Closing time: 0.5 s.
(minimum movement times, configurable. These times do not take into account the reaction of the access control system. The passage request memory function makes it possible to accelerate the flow: no closing between 2 requests)
- MCBF (average number of cycles between breakdowns), when respecting recommended maintenance: 2.500.000.
- IP40.
- CAN bus communication between the various modules making up the passage.
- Conforms to CE standards.
The Silicon protection strip on mobile leaf option is necessary to comply with the norms related to impact force.

Standard dimensions (mm)

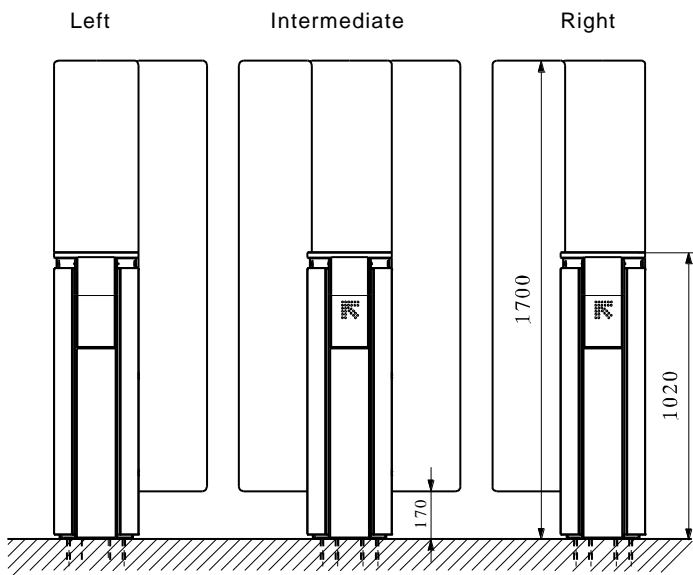

Options

- Integration of access control systems (badge reader, etc.) on housing or extension.
- Incorporation in the top cover of an operation pictogram, indicating the procedure to the user (waiting for a passage authorization, passage authorized, passage refused).
- Mobile leaf height: 1000, 1200 or 1900 mm and fixed leaf with equivalent height.
- Silicon protection strip on mobile leaf, for heights 1200, 1700, 1900 mm.
- Cells for fixed leaves.
- Enhanced protection cells.
- Trolley protection cells.
- Free opening cells (wheelchair detection).
- Personalized adhesive logo on fixed or mobile leaf.
- Painted stainless steel side panels (RAL colors).
- Wooden top cover (laminated beech).
- Stainless steel top cover.
- Power supply 120 VAC-60 Hz.
- Filled extension (stainless steel doors).
- Monitoring panel (requires IP interface option).
- Electromagnet locking the obstacles in the open position in case of power failure.

Precautions for use

- For security reasons, children (user smaller than 1 m tall) must be supervised by an adult at all times when in the vicinity of the unit and during passage through the lane
- A child must absolutely precede the accompanying adult when lane passage is required
- If habitual use by children is anticipated, Automatic Systems recommends the addition of all options required to optimize the level of protection.

